



2023 P CLASS NORTH ISLAND CHAMPIONSHIPS

Saturday 21st October 2023 & Sunday 22nd October 2023

at

Tauranga Yacht and Power Boat Club (Inc.)

Organising Authority:

TAURANGA YACHT AND POWER BOAT CLUB (Inc) [TYPBC]

PO Box 14352, Tauranga 3143. NEW ZEALAND

Phone (64) 07 578 5512 Fax 07 578 5595

Email office@yacht.org.nz

SAILING INSTRUCTIONS (SIs)

The notation '[NP]' in a rule of the sailing instructions (SIs) means that a boat may not protest another boat for breaking that rule. This changes RRS 60.1(a).

1 RULES

- 1.1** The event is governed by the rules as defined in The Racing Rules of Sailing and the Class Rules.
- 1.2** The Yachting New Zealand Safety Regulations Part 1 shall apply.
- 1.3** Racing rule A4.1 will be changed to 'a boat starting later than 5 minutes after starting signal will be scored DNS.'
- 1.4** Appendix T, *Arbitration*, will apply.

2 CHANGES TO SAILING INSTRUCTIONS

Any change to the sailing instructions will be posted before 0930 on the day it will take effect, except that any change to the schedule of races will be posted by 1800 on the day before it will take effect.

3 COMMUNICATIONS WITH COMPETITORS

- 3.1** Notices to competitors will be posted on the official notice board located in the basement of TYPBC.

3.2 The race office is located downstairs TYPBC.

3.3 [DP] From the first warning signal until the end of the last race of the day, except in an emergency, a boat shall not make voice and shall not receive voice that is not available to all boats.

4 CODE OF CONDUCT

[DP] Competitors and support persons shall comply with reasonable requests from race officials.

5 SIGNALS MADE ASHORE

5.1 Signals made ashore will be displayed next to the TYPBC Flagpole.

5.2 [DP] Flag D with one sound means 'Boats shall not leave the shore until this signal is made. The warning signal will not be made before the scheduled time or less than 30 minutes after flag D is displayed.'

6 SCHEDULE OF RACES

6.1

<i>Day/Date</i>	<i>Class</i>	<i>Number of races</i>	<i>Time of First Warning Signal</i>
21-10-2023	P Class	4	1125hr
22-10-2023	P Class	4	1125hr

6.2 One extra race per day may be sailed, provided that the class becomes no more than one race ahead of schedule.

6.3 To alert boats that a race or sequence of races will begin soon, the orange starting line flag will be displayed with one sound at least five minutes before a warning signal is made.

7 CLASS FLAGS

The class flag will be. A white flag with a Blue P.

8 RACING AREA

The races will be held within the confines of the Tauranga Harbour.

9 COURSES

9.1 The diagram in Attachment A show the course, including the approximate angles between legs, the order in which marks are to be passed, and the side on which each mark is to be left.

9.2 No later than the warning signal, the race committee signal vessel will display the course number on the stern or the committee vessel.

10 MARKS

Mark	Description	New mark description as provided in SI 13
1	A yellow cylindrical buoy approx. 1.2 meters high	A red cylindrical buoy approx. 1.2 meters high
2	A yellow cylindrical buoy approx. 1.2 meters high	
Start – Starboard End	Committee Vessel	
Start – Port End	A round Red Buoy	
Finish – Starboard End	Committee Vessel	
Finish – Port End	A round Red Buoy	

12 THE START

12.1 The starting line is between a staff displaying an orange flag on the committee vessel at the starboard end and the course side of the port-end starting mark.

12.2 A boat that does not start within 5 minutes after her starting signal will be scored Did Not Start without a hearing. This changes RRS A5.1 and A5.2.

13 CHANGE OF THE NEXT LEG OF THE COURSE

To change the next leg of the course, the race committee will lay a new mark (or move the finishing line) and remove the original mark as soon as practicable. When in a subsequent change a new mark is replaced, it will be replaced by an original mark.]

14 THE FINISH 14.1

The finishing line is between a staff displaying a blue flag on the finishing mark at the starboard end and the course side of the port end finishing mark.

15 PENALTY SYSTEM

RRS 44.1 is changed so that the Two-Turns Penalty is replaced by the One-Turn Penalty

16 TIME LIMITS [AND TARGET TIMES]

16.1 The Race Time Limit (see RRS 35), Target Time and the Finishing Window are shown in the table below.

Class	Target Time	Race Time Limit	Finishing Window
P Class	30 minutes	60minutes	15minutes

16.2 Boats failing to finish within the Finish Window after the first boat starts, sails the course, and finishes within the race time limit will be scored Did Not Finish without a hearing. This changes

RRS 35, A5.1 and A5.2 The Finishing Window is the time for boats to finish after the first boat sails the course and finishes. Boats failing to finish within the Finishing Window, and not subsequently retiring, penalized, or given redress, will be scored Time Limit Expired (TLE) without a hearing. A boat scored TLE shall be scored points for the finishing place one more than the points scored by the last boat that finished within the Finishing Window. This changes RRS 35, A5.1, A5.2 and A10.]

16.3 Failure to meet the Target Time will not be grounds for redress. This changes RRS 62.1(a).

17 HEARING REQUESTS

17.1 The protest time limit is 60 minutes after the last boat finishes the last race of the day or the race committee signals no more racing today, whichever is later. The time will be posted on the official notice board.

17.2 Hearing request forms are available from the race office at downstairs TYPBC.

17.3 Notices will be posted no later than 30 minutes after the protest time limit to inform competitors of hearings in which they are parties or named as witnesses.

17.4 Immediately after finishing a boat intending to protest shall, in addition to the requirements of RRS61.1(a), inform the race committee at the finishing line of her intention to protest and the identity of the boat(s) protested against. The protesting boat must receive an acknowledgement from the race committee. This changes RRS 61.

18 SCORING

18.1 3 races are required to be completed to constitute a series.

18.3 (a) When fewer than 6 races have been completed, a boat's series score is the total of her race scores.

(b) When from 6 to 8 races have been completed, a boat's series score is the total of her race scores excluding her worst score.

19 [DP][NP]SAFETY REGULATIONS

19.1 **Skippers shall sign on before going afloat and sign off after being afloat on the sign on sheet at the Race Office.**

19.2 A boat that retires from a race shall notify the race committee at the first reasonable opportunity.

20 REPLACEMENT OF CREW OR EQUIPMENT

20.1 [DP]Substitution of competitors is not allowed without prior written approval of the race committee .

20.2 [DP] Substitution of damaged or lost equipment is not allowed unless authorized in writing by the race committee. Requests for substitution shall be made to the committee at the first reasonable opportunity, which may be after the race.

21 EQUIPMENT AND MEASUREMENT CHECKS

21.1 A boat or equipment may be inspected at any time for compliance with the class rules, notice of race and sailing instructions.

21.2 [DP] When instructed by a race official on the water, a boat shall proceed to a designated area for inspection.

22 OFFICIAL VESSELS

Official vessels will be identified by the TYPBC burgee.

23 [DP][NP] SUPPORT TEAMS

23.1 Except when requested to participate in rescue operations, team leaders, coaches, and other support persons shall stay outside areas where boats are racing and are restricted to a 5 knot speed limit, from the time of the preparatory signal for the first start of a sequence of starts until all boats have finished or the race committee signals a postponement or abandonment of all races. The areas the boats are racing in is defined as the area inside the course and within 100 metres of any mark, lay line, starting line, finishing line or any area where any boat that is racing is sailing or may sail.

23.2 When flag V (with a long sound signal) is displayed on a committee boat all support boats are requested to remain afloat and assist all sailors.

23.3 All official and support vessels shall always have an engine safety cut out switch (kill cord) attached to the driver while the engine is running unless prior written exemption has been provided by the Organising Authority.

24 HAUL-OUT RESTRICTIONS

[DP] Unless otherwise directed by the Organising Authority, all competing boats and equipment shall be launched and retrieved from in front of the TYPBC.

25 PRIZES

Prizes will be given as follows.

First place North Island P Class Championship Trophy

Second and third places

First female competitor

26 RISK STATEMENT

RRS 3 states: 'The responsibility for a boat's decision to participate in a race or to continue to race is hers alone.' By participating in this event each competitor agrees and acknowledges that sailing is a potentially dangerous activity with inherent risks. These risks include strong winds and rough seas, sudden changes in weather, failure of equipment, boat handling errors, poor seamanship by other boats, loss of balance on an unstable platform and fatigue resulting in

increased risk of injury. **Inherent in the sport of sailing is the risk of permanent, catastrophic injury or death by drowning, trauma, hypothermia, or other causes.**

27 INSURANCE

27.1 Each participating boat shall be insured with valid third-party liability insurance with a minimum cover of \$1,000,000 per incident or the equivalent.

27.2 Support boats if they wish to enter the marina, **MUST** have a valid third-party liability insurance with a minimum cover of \$5,000,000 per incident or the equivalent. and a Certificate of insurance is to be presented at registration.

Attachment A – Illustrating the Course

A Windward-Leeward Course

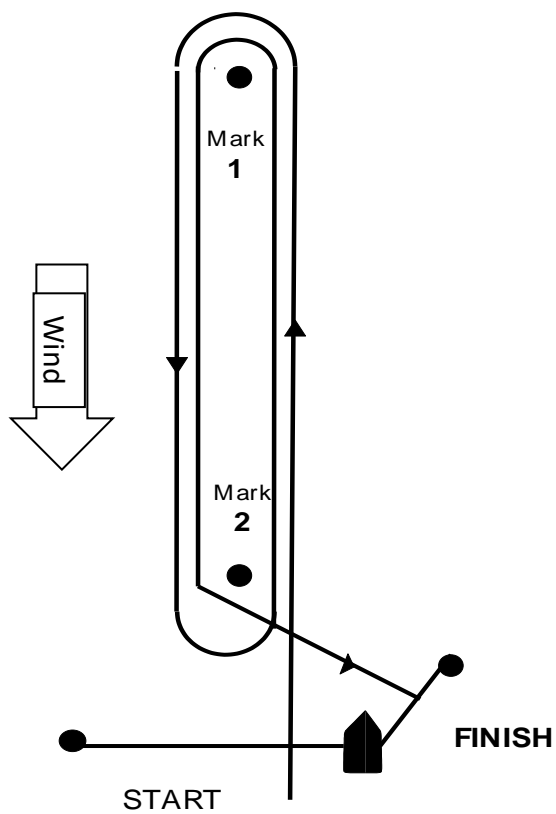

W1 START, 1, 2, FINISH.

W2 START, 1, 2, 1, 2, FINISH.

W3 START, 1, 2, 1, 2, 1, 2, FINISH.

W4 START, 1, 2, 1, 2, 1, 2, 1, 2, FINISH.

A Triangle Course- Windward-Leeward

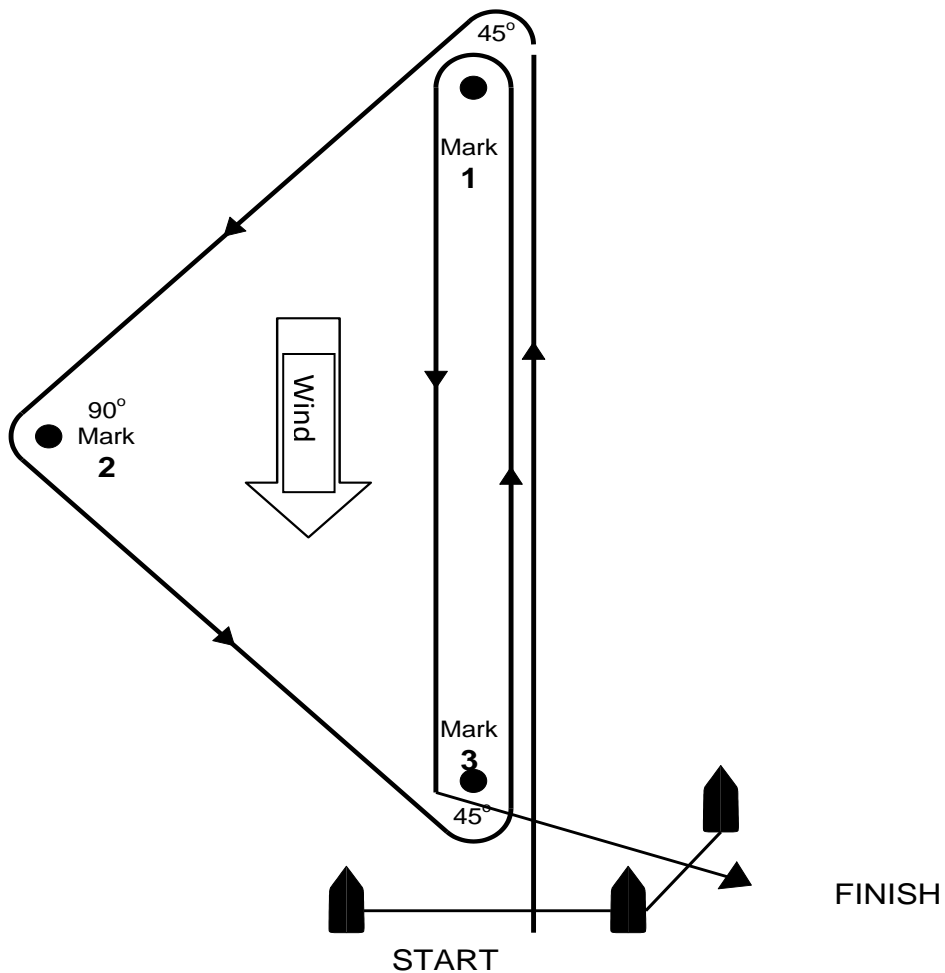

T 1 Start – 1 – 2 – 3 – Finish

T 2 Start – 1 – 2 – 3 – 1 – 3 – Finish

T 3 Start – 1 – 2 – 3 – 1 – 3 – 1 – 2 – 3 – Finish